

# Dispositivo di accoppiamento rapido "A"

Fast coupling device "A"

Dispositif d'accouplement rapide "A"

## AISI 304/316



### GG 25

GG 25	DN Ø	DN <sub>3</sub>	I	K	L	M	Mf	X	Y	Weight kg / lbs
RS 28.001 M	M 1"¼	F 2"	59	37,5	¾"	130	210	85	94	6,5 / 14.5
RS 28.002	M 1"½	F 2"	59	37,5	¾"	130	210	85	94	6,5 / 14.5
RS 28.003	M 2"	F 2"	59	37,5	¾"	130	210	85	94	6,5 / 14.5
RS 28.0021	40(PN10/16)	F 2"	59	37,5	¾"	130	210	85	94	6,5 / 14.5
RS 28.0031	50(PN10/16)	F 2"	59	37,5	¾"	130	210	85	94	6,5 / 14.5

AISI 304/316	DN Ø	DN <sub>3</sub>	I	K	L	M	Mf	X	Y	Weight kg / lbs
RS 28.001 MX	M 1"¼	F 2"	59	37,5	¾"	130	210	85	94	5,0 / 11.0
RS 28.002 X	M 1"½	F 2"	59	37,5	¾"	130	210	85	94	5,0 / 11.0
RS 28.003 X	M 2"	F 2"	59	37,5	¾"	130	210	85	94	5,0 / 11.0
RS 28.0021 X	40(PN10/16)	F 2"	59	37,5	¾"	130	210	85	94	5,0 / 11.0
RS 28.0031 X	50(PN10/16)	F 2"	59	37,5	¾"	130	210	85	94	5,0 / 11.0

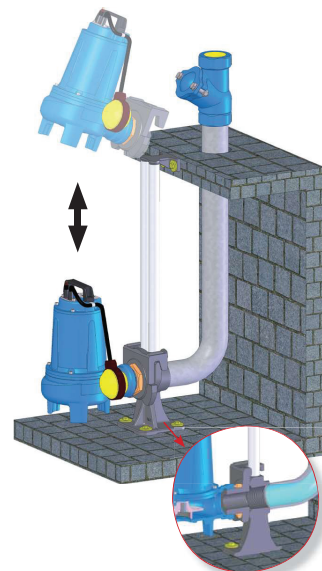
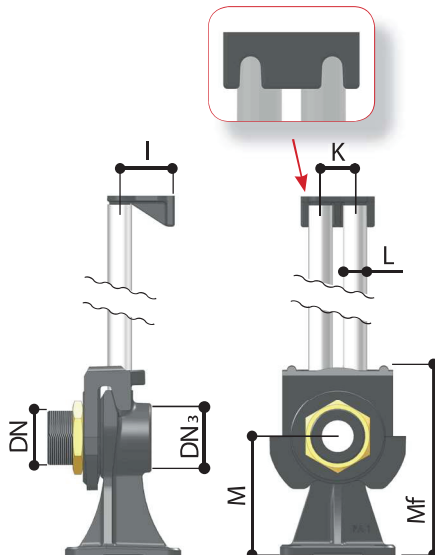
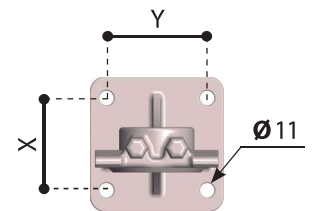
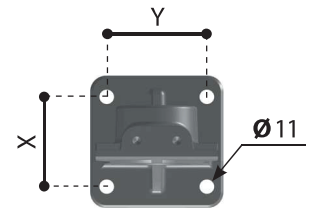

# Dispositivo di accoppiamento rapido "B"

Fast coupling device "B"

Dispositif d'accouplement rapide "B"



## GG 25

GG 25	DN	DN <sub>3</sub>	PN	PN <sub>3</sub>	I	K	L	M	Mf	X	Y	Z	Weight kg / lbs
<b>RS 28.004</b>	65	65	10/16	10/16	55	65	1 1/4	260	130	200	100	145	18,0 / 39.5
<b>RS 28.005</b> 10/10	80	80	10	10	75	100	2"	340	185	250	140	160	26,0 / 57.5
<b>RS 28.005</b> 16/10	80	80	16	10	75	100	2"	340	185	250	140	160	26,0 / 57.5
<b>RS 28.005</b> 16/16	80	80	16	16	75	100	2"	340	185	250	140	160	26,0 / 57.5
<b>RS 28.006</b>	100	100	10/16	10/16	75	100	2"	400	200	250	150	190	35,0 / 77.0

